



DF130 MOBILE FOAM UNIT

HIGH CAPACITY FOAM STATION FOR MAJOR RISKS

KEY USERS

- Petrochemicals
- Fuel Storage Sites
- Oil & Gas
- Mining
- Chemical Facilities
- Major Industrials
- Aviation
- Nuclear
- Marine

KEY FACTS

- Manufactured in the UK
- ISO9001 Quality Controlled
- Lloyds Certified
- One-Man Deployable
- Highly Mobile / Easy to Use
- 130 Litre Capacity
- 34,000 Litre Foam Output
- Long Running Times
- Suitable for all Foam Types
- Optional Marinised Version



MK II DF130 Marine Option

GENERAL DESCRIPTION

The DF130 Mobile Foam Unit is a one-man deployable, highly mobile, high capacity foam station designed principally for the protection of oil storage and loading terminals solvent stores, boiler rooms, engine compartments and many other high risk areas. Ergonomically designed and manufactured to exacting standards the DF130 simply requires connection to any suitable pressurized water supply and is capable of run times in excess of 20 minutes producing an output of over 34,000 litres of finished low expansion foam. Suitable for use with all foam types the DF130 is fitted with a Z-Series foam inductor for accurate proportioning between 1% and 6%. Foam discharge is via a HV-Series foam branchpipe designed to first expand the foam and then accelerate it to high velocity, producing long throws beyond the capability of many older designs. Connecting hoses are neatly stowed and deployed from the DF 130 with ease. The special Nova Polyamide hose used on the DF130 is designed to minimise kinking at low pressures enabling enhanced maneuverability in confined spaces. The DF130 is available in either Hi-Viz Yellow or International Orange and can be supplied in a fully Marined version with 316 stainless steel S-Series branchpipe and Gunmetal Z-Series Inductor on request. The DF130 is available with any International hose adaptors for compatibility to existing equipment.

Dimensions: 910 mm Long
710 mm Wide
1020 mm High

Weight: 70Kg (empty)

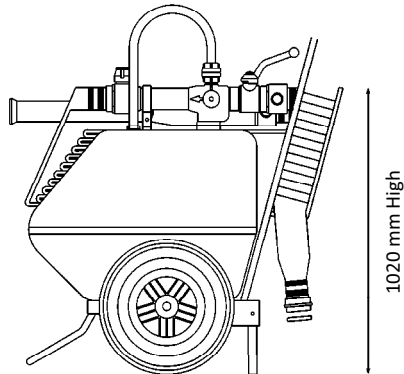
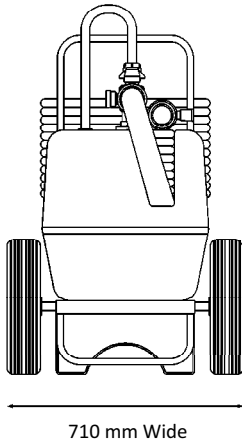
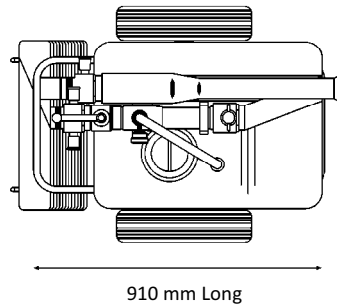

The DF 130 Mobile Foam Unit range is built under an ISO9001 Quality Management Standard from top quality materials including a high quality GRP foam tank, corrosion resistant plastic coated steel frame and solid rubber, non-puncture, tyres.

GENERAL DESIGN

The Delta DF130 range of Mobile Foam Units are the culmination of extensive design and development work over many years resulting in a superior, high performance product suited to a wide spectrum of applications around the world.



Componentry

The DF130 is fitted with the Z-Series Variable Inductor allowing for accurate foam proportioning between 1% & 6%. The HV-Series Branchpipe delivers the foam at high velocity providing fast, effective foam coverage over the risk area laying down a protective blanket of foam suppressing flammable vapours and preventing fire spread.



Connectivity

The DF130 has 2 x 15m lengths of 45mm Nova Polyamide 'all nylon' hose which is neatly stowed for fast deployment. Nova Hose is designed to resist kinking at low pressures enabling ease of maneuverability and maintaining performance at all times. Any type of International hose fitting can be supplied to ensure compatibility with existing equipment.



Foam Tank

The 130 litre capacity foam tank is manufactured from chemically resistant GRP and is fitted with a 'quick-fill' twist off filler cap easily located on the top of the tank. A transparent sight gauge allows the operator to assess foam levels with ease. A Tag Plate provides full traceability for every unit detailing a unique serial number and product specification.



Durability

The DF130 has a corrosion resistant plastic coated frame (handle and chassis) fitted with 400mm wide solid rubber tyres impervious to punctures making the DF130 an 'all-terrain' unit suitable for use on rough ground and for maneuvering over obstacles. An integral support arm stabilises the DF130 when stationary.

THE RANGE

The DF130 Mobile Foam Unit is available in a choice of three flow rates, 225, 450 or 900 litres per minute and is supplied with either light alloy fittings for Industrial/In-shore applications or Gunmetal fittings for Marine/Off-shore applications. A fully Marinised MK II option is also available for extreme, harsh environment use.

All models are available with either Low or Medium Expansion Foam Branchpipes.

Product Code	Expansion	Flow L/Min	Fitting Options	Colour Options	Application
FEP700002	Low Ex	225	Light Alloy	Hi-Viz Yellow or International Orange	Industrial/In-shore
FEP700001	Low Ex	225	Gunmetal	Hi-Viz Yellow or International Orange	Marine/Off-shore
FEP710002	Low Ex	450	Light Alloy	Hi-Viz Yellow or International Orange	Industrial/In-shore
FEP710001	Low Ex	450	Gunmetal	Hi-Viz Yellow or International Orange	Marine/Off-shore
FEP720002	Med Ex	225	Light Alloy	Hi-Viz Yellow or International Orange	Industrial/In-shore
FEP720001	Med Ex	225	Gunmetal	Hi-Viz Yellow or International Orange	Marine/Off-shore
FEP760002	Med Ex	450	Light Alloy	Hi-Viz Yellow or International Orange	Industrial/In-shore
FEP760001	Med Ex	450	Gunmetal	Hi-Viz Yellow or International Orange	Marine/Off-shore
FEP750001	Low Ex	225	Gunmetal	Hi-Viz Yellow or International Orange	Harsh Environment
FEP710003	Low Ex	450	Gunmetal	Hi-Viz Yellow or International Orange	Harsh Environment

Available with a choice of International hose connections to suit the customer's specific needs the DF130 is an excellent choice for rapid, one-man deployment, risk protection.